

OAW-IAP92 and OAW-IAP93 Wireless Access Point

Installation Guide

About the Alcatel-Lucent OAW-IAP92/OAW-IAP93

The Alcatel-Lucent OAW-IAP92 and OAW-IAP93 are single-radio, dual-band wireless access points that support the IEEE 802.11n standard for high-performance WLAN. These access points use MIMO (Multiple-in, Multiple-out) technology and other high-throughput mode techniques to deliver high-performance, 802.11n 2.4 GHz or 5 GHz functionality while simultaneously supporting existing 802.11a/b/g wireless services.

The Alcatel-Lucent OAW-IAP92/OAW-IAP93 access point provides the following capabilities:

- Wireless transceiver
- Protocol-independent networking functionality
- IEEE 802.11a/b/g/n operation as a wireless access point
- IEEE 802.11a/b/g/n operation as a wireless air monitor
- Compatibility with IEEE 802.3af PoE



The Alcatel-Lucent OAW-IAP92/OAW-IAP93 requires Alcatel-Lucent Instant 5.0.1 or later.

Package Contents

- OAW-IAP92 or OAW-IAP93 access point
- Installation Guide



Inform your supplier if there are any incorrect, missing, or damaged parts. If possible, retain the carton, including the original packing materials. Use these materials to repack and return the unit to the supplier if needed.

Figure 1 OAW-IAP92/OAW-IAP93 (OAW-IAP92 Shown)



OAW-IAP92/OAW-IAP93 Hardware Overview

Figure 2 Front (OAW-IAP92 Shown)

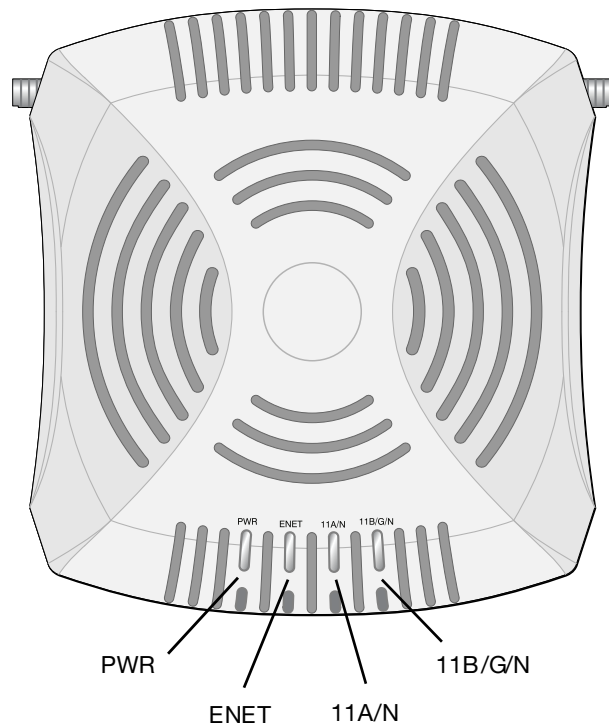

LEDs

- PWR: Indicates whether or not the OAW-IAP92/OAW-IAP93 is powered-on
- ENET: Indicates the status of the OAW-IAP92/OAW-IAP93's Ethernet port
- 11A/N: Indicates the status of the 802.11a/n radio
- 11B/G/N: Indicates the status of the 802.11b/g/n radio

For information about the OAW-IAP92/OAW-IAP93's LED behavior, see Table 1.

Figure 3 Rear (OAW-IAP92 Shown)

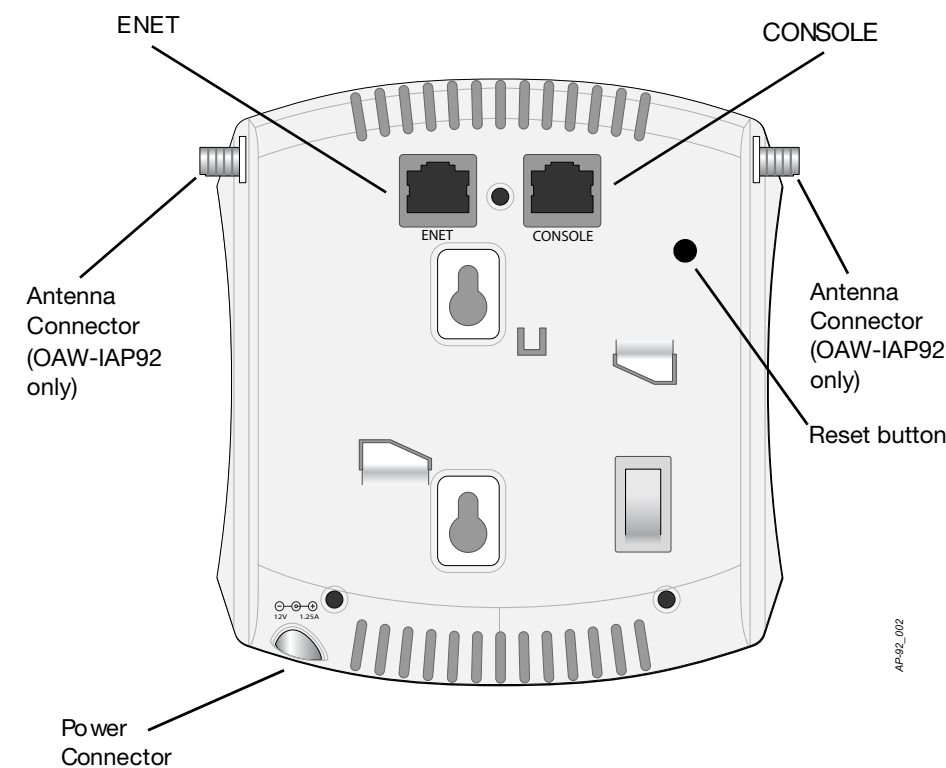

Console Port

Use the console port to connect to a terminal for direct local management.

Ethernet Port

OAW-IAP92/OAW-IAP93 is equipped with a single 10/100/1000Base-T (RJ-45) auto-sensing, MDI/MDX wired-network connectivity port. This port supports IEEE 802.3af Power over Ethernet (PoE) compliance, accepting 48VDC as a standard defined Powered Device (PD) from a Power Sourcing Equipment (PSE) such as a PoE midspan injector, or network infrastructure that supports PoE.

DC Power Socket

If PoE is not available, an optional Alcatel-Lucent IAP AC-DC adapter kit (sold separately) can be used to power the OAW-IAP92/OAW-IAP93.

Reset Button

The reset button can be used to return the IAP to factory default settings. To reset the IAP:

1. Power off the IAP.
2. Press and hold the reset button using a small, narrow object, such as a paperclip.
3. Power-on the IAP without releasing the reset button. The power LED will flash within 5 seconds.
4. Release the reset button.

The power LED will flash again within 15 seconds indicating that the reset is completed. The IAP will now continue to boot with the factory default settings.

External Antenna Connectors

The OAW-IAP92 is designed for use with external antennas. The OAW-IAP93 is equipped with internal antennas.

Before You Begin



FCC Statement: Improper termination of access points installed in the United States configured to non-US model switches will be in violation of the FCC grant of equipment authorization. Any such willful or intentional violation may result in a requirement by the FCC for immediate termination of operation and may be subject to forfeiture (47 CFR 1.80).

EU Statement:

Lower power radio LAN product operating in 2.4 GHz and 5 GHz bands. Please refer to the *Alcatel-Lucent Instant User Guide* for details on restrictions.



Produit réseau local radio basse puissance opérant dans la bande fréquence 2.4 GHz et 5 GHz. Merci de vous référer au *Alcatel-Lucent Instant User Guide* pour les détails des restrictions.

Low Power FunkLAN Produkt, das im 2.4 GHz und im 5 GHz Band arbeitet. Weitere Informationen bezüglich Einschränkungen finden Sie im *Alcatel-Lucent Instant User Guide*.

Apparati Radio LAN a bassa Potenza, operanti a 2.4 GHz e 5 GHz. Fare riferimento alla *Alcatel-Lucent Instant User Guide* per avere informazioni dettagliate sulle restrizioni.

IAP Pre-Installation Checklist

Before installing your OAW-IAP92/OAW-IAP93 access point, be sure that you have the following:

- CAT5 UTP cable of required length
- One of the following power sources:
 - IEEE 802.3af-compliant Power over Ethernet (PoE) source
 - Alcatel-Lucent IAP AC-DC adapter kit (sold separately)
- Alcatel-Lucent Switch provisioned on the network:
 - Layer 2/3 network connectivity to your access point

One of the following network services:

- Alcatel-Lucent Discovery Protocol (ADP)
- DNS server with an "A" record
- DHCP Server with vendor-specific options

Summary of the Setup Process



It is important that you verify the items listed under *IAP Pre-Installation Checklist* before you attempt to set up and install an OAW-IAP92/OAW-IAP93.

Successful setup of an OAW-IAP92/OAW-IAP93 access point consists of five tasks, which must be performed in this order:

1. Verify pre-installation connectivity.
2. Identify the specific installation location for each IAP.
3. Install each IAP.
4. Verify post-installation connectivity.
5. Configure each IAP.



Alcatel-Lucent, Inc., in compliance with governmental requirements, has designed the OAW-IAP92/OAW-IAP93 access points so that only authorized network administrators can change the settings. For more information about IAP configuration, refer to the *Alcatel-Lucent Instant Quick Start Guide* and *Alcatel-Lucent Instant User Guide*.



Access points are radio transmission devices and as such are subject to governmental regulation. Network administrators responsible for the configuration and operation of access points must comply with local broadcast regulations. Specifically, access points must use channel assignments appropriate to the location in which the access point will be used.

Verifying Pre-Installation Connectivity

Before you install APs in a network environment, make sure that the APs are able to locate and connect to the switch after power on. Specifically, you must verify the following conditions:

- When connected to the network, each IAP is assigned a valid IP address
- APs are able to locate the switch

Refer to the *Alcatel-Lucent Instant Quick Start Guide* for instructions on locating and connecting to the switch.

Identifying Specific Installation Locations

You can mount the OAW-IAP92/OAW-IAP93 access point on a wall or on the ceiling. Each location should be as close as possible to the center of the intended coverage area and should be free from obstructions or obvious sources of interference. These RF absorbers/reflectors/interference sources will impact RF propagation and should have been accounted for during the planning phase and adjusted for in VisualRF.

Identifying Known RF Absorbers/Reflectors/Interference Sources

Identifying known RF absorbers, reflectors, and interference sources while in the field during the installation phase is critical. Make sure that these sources are taken into consideration when you attach an IAP to its fixed location.

RF absorbers include:

- Cement/concrete—Old concrete has high levels of water dissipation, which dries out the concrete, allowing for potential RF propagation. New concrete has high levels of water concentration in the concrete, blocking RF signals.
- Natural Items—Fish tanks, water fountains, ponds, and trees
- Brick

RF reflectors include:

- Metal Objects—Metal pans between floors, rebar, fire doors, air conditioning/heating ducts, mesh windows, blinds, chain link fences (depending on aperture size), refrigerators, racks, shelves, and filing cabinets.
- Do not place an IAP between two air conditioning/heating ducts. Make sure that APs are placed below ducts to avoid RF disturbances.

RF interference sources include:

- Microwave ovens and other 2.4 or 5 GHz objects (such as cordless phones)
- Cordless headset such as those used in call centers or lunch rooms

Installing the IAP



Installation and service of Alcatel-Lucent Networks products should be performed by Professional Installers. Additional antenna and transmit power information for Professional Installers can be found at <https://support.alcatel-lucent.com>.



If you are installing an OAW-IAP92, be sure to attach the antennas before mounting the IAP.

Using the Integrated Wall-Mounting Slots

The keyhole-shaped slots on the back of the IAP can be used to attach the device upright to an indoor wall or shelf. When you choose the mounting location, allow additional space at the right of the unit for cables.

1. Since the ports are on the back of the device, make sure that you mount the IAP in such a way that there is a clear path to the Ethernet port, such as a pre-drilled hole in the mounting surface.
2. At the mounting location, install two screws on the wall or shelf, 1 7/8 inches (4.7cm) apart. If you are attaching the device to drywall, Alcatel-Lucent recommends using appropriate wall anchors (not included).
3. Align the mounting slots on the rear of the IAP over the screws and slide the unit into place (see Figure 4).

Figure 4 Installing the OAW-IAP92/OAW-IAP93 Access Point on a Wall

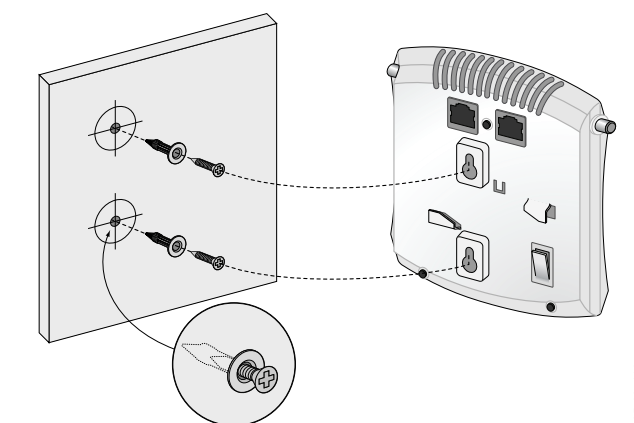

Using the Integrated Ceiling Tile Rail Slots

The snap-in tile rail slots on the rear of the IAP can be used to securely attach the device directly to a 15/16" wide, standard ceiling tile rail.



Make sure the IAP fits securely on the ceiling tile rail when hanging the device from the ceiling; poor installation could cause it to fall.

1. Pull the necessary cables through a prepared hole in the ceiling tile near where the IAP will be placed.
2. If necessary, connect the console cable to the console port on the back of the IAP.
3. Hold the IAP next to the ceiling tile rail with the ceiling tile rail mounting slots at approximately a 30-degree angle to the ceiling tile rail (see Figure 5). Make sure that any cable slack is above the ceiling tile.

Figure 5 Orienting the Ceiling Tile Rail Mounting Slots

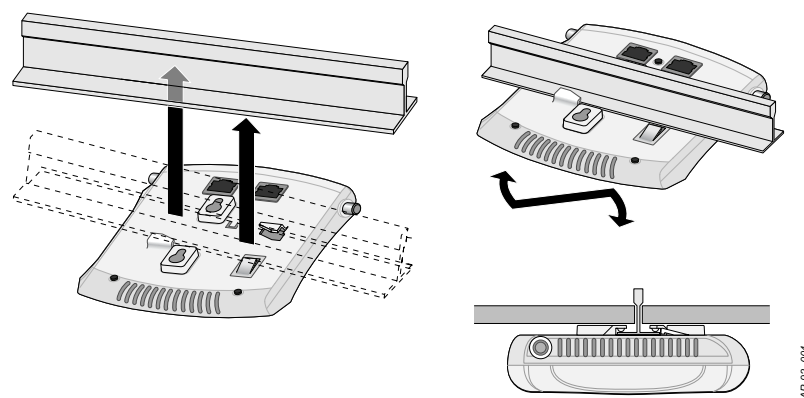

- Pushing toward the ceiling tile, rotate the IAP clockwise until the device clicks into place on the ceiling tile rail.

Connecting Required Cables

Install cables in accordance with all applicable local and national regulations and practices.

Ethernet Ports

The RJ45 Ethernet port (ENET) supports 10/100/1000Base-T auto-sensing MDI/MDX connections. Use these ports to connect the IAP to a twisted pair Ethernet LAN segment or directly to an Alcatel-Lucent Switch. Use a 4- or 8-conductor, Category 5 UTP cable up to 100 m (325 feet) long.

The 10/100/1000 Mbps Ethernet port is on the back of the IAP. The port has an RJ-45 female connector with the pin-outs shown in the figure below.

Figure 6 Gigabit Ethernet Port Pin-Out

1000Base-T Gigabit Ethernet Port	RJ-45 Female Pin-Out	Signal Name	Function
	1	BI_DA+	Bi-directional pair +A
	2	BI_DA-	Bi-directional pair -A
	3	BI_DB+	Bi-directional pair +B
	4	BI_DC+	Bi-directional pair +C
	5	BI_DC-	Bi-directional pair -C
	6	BI_DB-	Bi-directional pair -B
	7	BI_DD+	Bi-directional pair +D
	8	BI_DD-	Bi-directional pair -D

Serial Console Port

The serial console port (Console) allows you to connect the IAP to a serial terminal or a laptop for direct local management. This port is an RJ-45 female connector with the pinouts described in Figure 7. Connect this port directly to a terminal or terminal server using an Ethernet cable.

Use a modular adapter to convert the RJ-45 (female) connector on the IAP to a DB-9 (male) connector, and connect the adapter to a laptop using an RS-232 cable. See Figure 8 for connector details of the adapter.

Figure 7 Serial Port Pin-Out

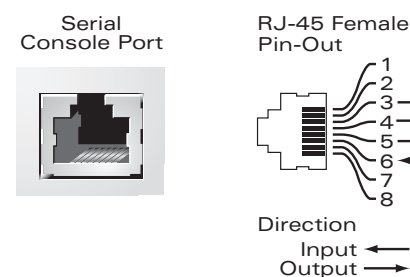
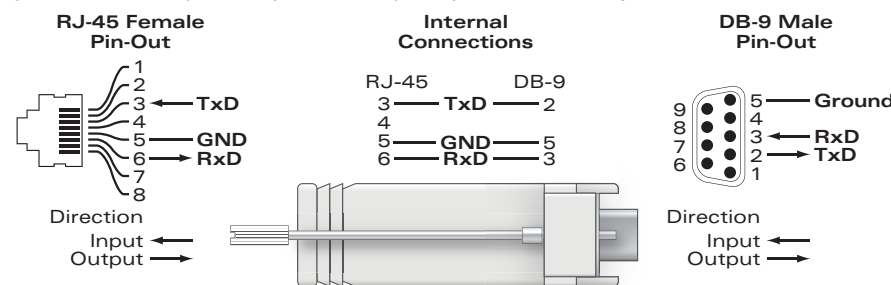

Figure 8 RJ-45 (Female) to DB-9 (Male) Modular Adapter Conversion



Power Connection

The OAW-IAP92/OAW-IAP93 has a single 12V DC power jack socket to support powering through an AC-to-DC power adapter.



If both POE and DC power are available, the IAP uses POE even when there is not enough POE voltage available to power the IAP.

Verifying Post-Installation Connectivity

The integrated LEDs on the IAP can be used to verify that the IAP is receiving power and initializing successfully (see Table 1). Refer to the *Alcatel-Lucent*

Instant Quick Start Guide for further details on verifying post-installation network connectivity.

Table 1 OAW-IAP92/OAW-IAP93 Series LED Meanings

LED	Color/State	Meaning
PWR	Off	No power to IAP
	Green flashing	System initializing
	Red steady	System failed to initialize, contact TAC
	Green steady	Power on, device ready
ENET (10/100/1000 Mbps)	Off	No link
	Green on	1000 Mbps link
	Amber on	10/100 Mbps link
11A/N	Off	5 GHz radio is disabled
	Amber	5 GHz radio enabled in WLAN mode
	Green	5 GHz radio enabled in 11n mode
	Green flashing	5 GHz Air Monitor or RF Protect mode
11B/G/N	Off	2.4 GHz radio disabled
	Amber	2.4 GHz radio enabled in WLAN mode
	Green	2.4 GHz radio enabled in 11n mode
	Green flashing	2.4 GHz Air Monitor or RF Protect mode

Product Specifications

Electrical

- Ethernet:
 - 1 x 10/100/1000Base-T auto-sensing Ethernet RJ-45 Interfaces
 - MDI/MDX
 - IEEE 802.3 (10Base-T), IEEE 802.3u (100Base-T), IEEE 802.3ab (1000Base-T)
 - Power over Ethernet (IEEE 802.3af compliant), 48V DC/350mA (see Figure 6 for pin configuration)
- Power:
 - 12 VDC power interface, supports powering through an AC-to-DC power adapter



If a power adapter other than the one provided by Alcatel-Lucent Networks is used in the US or Canada, it should be cULus (NRTL) Listed, with an output rated 12 VDC, minimum 1.25A, marked "LPS" or "Class 2," and suitable for plugging into a standard power receptacle in the US and Canada.

For additional specifications on this product, please refer to the data sheet. The data sheet can be found at www.alcatel-lucent.com.

Proper Disposal of Alcatel-Lucent Equipment

For the most current information about Global Environmental Compliance and Alcatel-Lucent products, see our website at www.alcatel-lucent.com.

Waste of Electrical and Electronic Equipment



Alcatel-Lucent products at end of life are subject to separate collection and treatment in the EU Member States, Norway, and Switzerland and therefore are marked with the symbol shown at the left (crossed-out wheeled bin). The treatment applied at end of life of these products in these countries shall comply with the applicable national laws of countries implementing Directive 2002/96/EC on Waste of Electrical and Electronic Equipment (WEEE).

European Union RoHS



Alcatel-Lucent products also comply with the EU Restriction of Hazardous Substances Directive 2002/95/EC (RoHS). EU RoHS restricts the use of specific hazardous materials in the manufacture of electrical and electronic equipment. Specifically, restricted materials under the RoHS Directive are Lead (including Solder used in printed circuit assemblies), Cadmium, Mercury, Hexavalent Chromium, and Bromine. Some Alcatel-Lucent products are subject to the exemptions listed in RoHS Directive Annex 7 (Lead in solder used in printed circuit assemblies). Products and packaging will be marked with the "RoHS" label shown at the left indicating conformance to this Directive.

China RoHS



Alcatel-Lucent products also comply with China environmental declaration requirements and are labeled with the "EFUP 10" label shown at the left.

有毒有害物质声明
Hazardous Materials Declaration

部件名称 (Parts)	有毒有害物质或元素 (Hazardous Substance)					
	铅 (Pb)	汞 (Hg)	镉 (Cd)	六价铬 (Cr ⁶⁺)	多溴联苯 (PBB)	多溴二苯醚 (PBDE)
电路板 (PCB Boards)	×	○	○	○	○	○
机械组件 (Mechanical Sub-Assemblies)	×	○	○	○	○	○

○: 表示该有毒有害物质在该部件所有均质材料中的含量均在 SJ/T11363-2006 标准规定的限量要求以下。
Indicates that the concentration of the hazardous substance in all homogeneous materials in the parts is below the relevant threshold of the SJ/T11363-2006 standard.

×: 表示该有毒有害物质至少在该部件的某一均质材料中的含量超出 SJ/T11363-2006 标准规定的限量要求。
Indicates that the concentration of the hazardous substance of at least one of all homogeneous materials in the parts is above the relevant threshold of the SJ/T11363-2006 standard.

对销售之目的所售产品, 本表显示, 供应链的电子产品信息可能包含这些物质。
This table shows where these substances may be found in the supply chain of electronic information products, as of the date of sale of the enclosed product.

此标志为针对所涉产品的环保使用期限标志。某些零件会有一个不同的环保使用期限 (例如, 电池单元模块) 贴在其产品上。
此环保使用期限只适用于产品是在产品手册中所规定的条件下工作。
The Environment-Friendly Use Period (EFUP) for all enclosed products and their parts are per the symbol shown here. The Environment-Friendly Use Period is valid only when the product is operated under the conditions defined in the product manual.

Safety and Regulatory Compliance

Alcatel-Lucent Networks provides a multi-language document that contains country-specific restrictions and additional safety and regulatory information for all Alcatel-Lucent access points. This document can be viewed or downloaded from the following location: <https://service.esd.alcatel-lucent.com>.

The device will be electronically labeled and the FCC ID will be displayed via the switch WebUI under the **About** menu.



Alcatel-Lucent access points must be installed by a professional installer. The professional installer is responsible for ensuring that grounding is available and it meets applicable local and national electrical codes.



RF Radiation Exposure Statement: This equipment complies with FCC RF radiation exposure limits. This equipment should be installed and operated with a minimum distance of 7.87 inches (20cm) between the radiator and your body for 2.4 GHz and 5 GHz operations. This transmitter must not be co-located or operating in conjunction with any other antenna or transmitter. When operated in the 5.15 to 5.25 GHz frequency range, this device is restricted to indoor use.

EMC Compliance and Warning Statement

- IEC 60601-1-2: 2007
- EN 60601-1-2: 2007

This equipment has been tested and found to comply with the limits of the standard for medical devices, IEC 60601-1-2:2007. The unit also complies with the requirements of EN 60601-1-2:2007, providing the presumption of compliance to the European Union's Medical Device Directive 2007/47/EC. The limits are designed to provide reasonable protection against harmful interference in a typical medical installation. This equipment generates, uses and can radiate radio frequency energy, and, if not installed and used in accordance with the manufacturer's instructions may cause harmful interference to other devices in the vicinity. However, there is no guarantee that interference will not occur in a particular installation. If this equipment causes interference with other devices, which may be determined by turning the equipment off and on, the user is encouraged to try and correct the interference by one or more of the following measures:

- Reorient or relocate the device receiving the interference.
- Increase the separation between the equipment.
- Connect the equipment into an outlet on a circuit different from that to which the other device(s) are connected.
- Consult the manufacturer or field service technician for help.

The Models OAW-IAP92 and OAW-IAP93 do not have an Applied Part as defined in IEC 60601-1. The protection against electric shock is Class II.

Device is not protected against ingress of liquids and has a protection class of IPX0 as defined by IEC 60601-1 and IEC 60529. Equipment not suitable for use in the presence of flammable mixtures.

The unit is considered "Continuous Operation" equipment as defined by IEC 60601-1.

Power Consumption – 48 VDC 802.3af power over Ethernet or 12VDC, 1.25A for external AC supplied power (adapter sold separately); Maximum power consumption - 10W.

Mechanical Dimensions: 120mm x 130mm x 55mm; 255g.

Environmental: Operating Temp: 0° C to +50° C (+32° F to +122° F); Humidity: 5 to 95% non-condensing. Storage Temp: -40° C to +70° C (-40° F to +158° F).

OAW-IAP92 and OAW-IAP93 Wireless Access Point Installation Guide

Contacting Alcatel-Lucent

Table 1

Web Site Support	
Main Site	http://www.alcatel-lucent.com/enterprise
Support Site	https://service.esd.alcatel-lucent.com/

Table 2

Telephone Support	
North America	1-800-995-2696
Latin America	1-877-919-9526
Europe	+33 (0) 38 855 6929
Asia Pacific	+65 6240 8484
Worldwide	1-818-878-4507

Copyright

© 2011 Alcatel-Lucent, Inc. All rights reserved. Specifications in this manual are subject to change without notice. Originated in the USA.

Any other trademarks appearing in this manual are the property of their respective companies.

Legal Notice

This hardware product is protected by the Alcatel-Lucent Limited Lifetime warranty



www.alcatel-lucent.com
26801 West Agoura Road
Calabasas, CA 91301

OAW-IAP92 and OAW-IAP93 Wireless Access Point | Installation Guide
Part Number 0510918-01 | April 2011